

The Gas Family

Champlain Model 8304

The Champlain will add a touch of classic style to your room.



Features

Artfully balanced fire

The Champlain gas stove has been carefully designed to present a balanced, gently flickering fire on both low and high settings.

Convenient control

The Champlain 8304 maintains a standing pilot which will shut off after 7 days of inactivity. It can be run manually, with a standard or programmable thermostat, or with an optional remote control.

True efficiency

The Champlain includes a cast iron heat exchanger above the fire. Natural convective airflow moves air through the vents of the stove to warm your room.

Gas Burning Stove

Champlain 8304



Dimensions

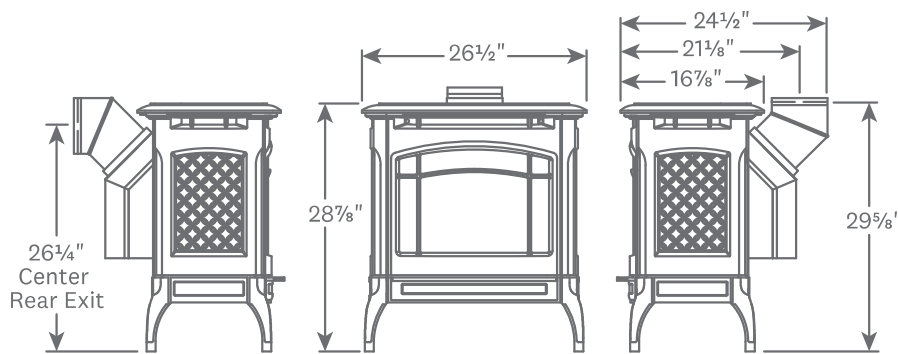

Clearances

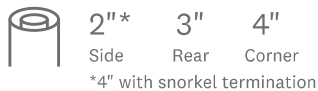

Floor Protection:
Non-combustible surface or wood floor

Finish Options

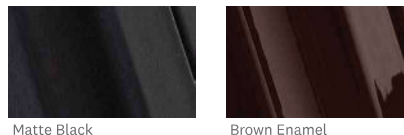

Specifications

- Heats up to.....1,800 sq ft
- Steady State Efficiency 74.6%
- P.4.1.09 Efficiency 67.9%
- Burn Rate Range NG.....21k-35k BTUs/hr
- Burn Rate Range LP21k-35k BTUs/hr
- Venting45°, 4" x 6-5/8" DV
- Ignition System.....SIT 820, 7 day timeout
- Burner.....Pan Burner
- Convection Blower.....Optional
- Remote ControlOptional
- Safety Barrier Screens.....Included
- LP Conversion KitIncluded
- Mobile Home Certified Yes
- Weight 220 lbs.

Accessories

- Convection Blower.....93-57020
- Remote Control Kit.....90-56914

Note: All information is for reference only.
Refer to the owner's manual for full specification and installation details.